

## General Installation Manual

### HIT Photovoltaic Module

VBHNxxxSE series

VBHHxxxAE series

#### Model No.

- VBHN240SE10 (HIT-N240SE10)
- VBHN240SE11 (HIT-N240SE11)
- VBHN235SE10 (HIT-N235SE10)
- VBHN235SE11 (HIT-N235SE11)
- VBHN230SE10 (HIT-N230SE10)
- VBHN230SE11 (HIT-N230SE11)

#### Model No.

- VBHH250AE01 (HIT-H250E01)
- VBHH250AE02 (HIT-H250E02)
- VBHH245AE01 (HIT-H245E01)
- VBHH245AE02 (HIT-H245E02)
- VBHH240AE01 (HIT-H240E01)
- VBHH240AE02 (HIT-H240E02)

Thank you for choosing Panasonic HIT photovoltaic (PV) modules. Please read this manual completely before installation or use of Panasonic HIT PV modules. With proper operation and maintenance, Panasonic HIT PV modules will provide you with clean, renewable solar electricity for many years. This manual contains important installation, maintenance and safety information. The word "module" as used in this manual refers to one or more PV modules. Retain this manual for future reference.

SANYO is part of the Panasonic Group and is in charge of the manufacturing process for Panasonic HIT solar modules.

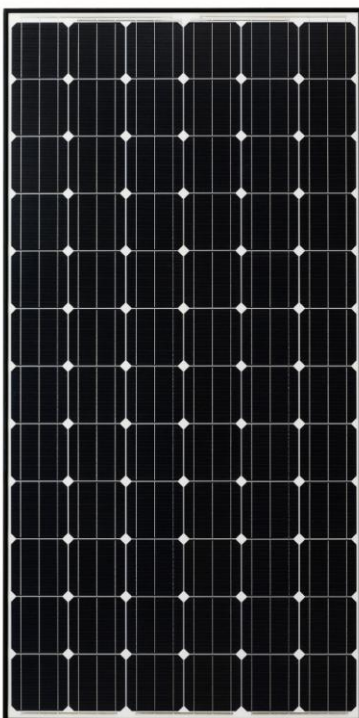

VBHNxxxSE series

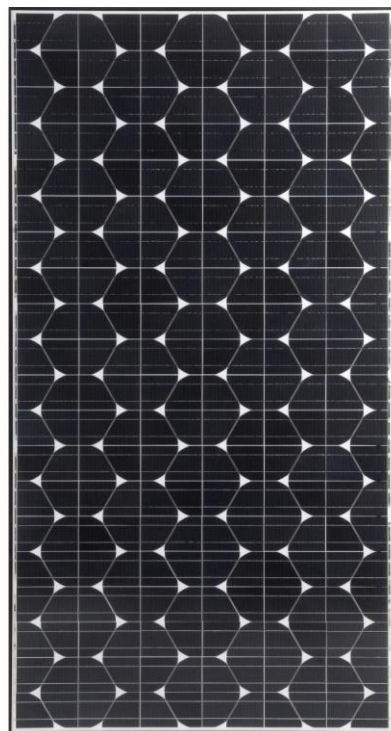

VBHHxxxAE series

## Contents

Please read before installation

### Safety Precautions

- General Information :2
- Warning :2
- Cautions :2
- General Safety :2

### Installation

- General :3
- Notes on Installation :3
- Operating Conditions :3
- Special Conditions :3

### Specifications

- Note on Specifications :3
- Application Class of Product :3
- Fire class of Product :3
- Mechanical Loading :3

Certifications :3

### Wiring

- General :3
- Module Wiring :4
- Array Wiring :4
- Earth Ground Wiring :4
- Module Terminations :4
- Junction Box and Terminals :4
- Conduit :4

Bypass Diodes :4

Maintenance :4

Disclaimer of Liability :5

Customer Services :5

## Safety Precautions

### General Information

The installation of modules requires a great degree of skill and should only be performed by qualified licensed professionals, including, without limitation, licensed contractors and licensed electricians.

### WARNING

- All instructions should be read and understood before attempting to install, wire, operate, and maintain the module. Contact with electrically active parts of the module such as terminals can result in burns, sparks, and lethal shock whether the module is connected or disconnected.
- The installer assumes the risk of all injury that might occur during installation, including, without limitation, the risk of electric shock.
- The modules generate DC electrical energy when exposed to sunlight or other light sources. Although single modules produce only a low voltage and current, shocks and burns are still a potential hazard.
- To avoid the hazard of electric shock and injury, cover the entire front surface of the modules with a dense, opaque material such as a cardboard box, during installation and handling of the modules.
- The shock hazard increases as modules are connected in parallel, producing higher current, and as modules are connected in series, producing higher voltages.
- The shock hazard increases as modules with nominal open-circuit voltage (Voc) in excess of 50 V, and/or modules rated for maximum system voltage in excess of 50 V.
- To avoid the hazard of electric shock, work only in dry conditions, with dry modules and dry tools.
- Do not stand or step on a module to avoid the hazard of injury and damage to the module.
- Do not puncture or damage the back sheet of a module, to avoid the hazard of electric shock and fire.
- To avoid the hazard of electric shock and injury, children and unauthorized persons should not be allowed near the installation of modules.

- To avoid the hazard of electric shock and injury, be sure to completely ground all modules.
- To avoid the hazard of electric shock, fire, and injury, do not disassemble the module, or remove any part installed by the manufacturer.
- Unauthorized persons—except the qualified licensed professional—should not open the cover of the junction box to avoid the hazard of electric shock.
- Do not touch terminals while a module is exposed to light. Provide suitable guards to prevent yourself from direct contact with 30 VDC or greater to avoid the hazard of electric shock or injury.
- When carrying a module, two or more people should carry it by its frame and wear non-slip gloves (to avoid injury by a slipping module, to a foot, or cuts by the edge of a frame, and so on).
- Do not carry a module by its wires or junction box, to avoid the hazard of electric shock, injury or damage to the module.
- Do not drop anything on the surfaces of a module, to avoid the hazard of electric shock, injury, and damage.
- To avoid the hazard of electric shock and fire, be sure that all other system components are compatible, and they do not subject the module to mechanical or electrical hazards.
- Since sparks may occur, do not install the module where flammable gases or vapors are present.
- Never leave a module unsupported or unsecured.
- Do not drop a module.
- Do not use or install broken modules to avoid the hazard of fire, electric shock, and injury.
- Do not artificially concentrate sunlight on a module to avoid the hazard of fire or damage.
- Do not touch the junction box terminals to avoid the hazard of electric shock and injury.
- Do not change the wiring of bypass diodes to avoid the hazard of electric shock and injury.
- Do not disconnect terminals while modules generate electricity and connect electrical load to avoid the hazard of electrical shock.
- Do not touch a module unnecessarily. The glass surface

and frames get hot. There is a risk of burn.

### CAUTIONS

- Use a module for its intended purpose only.
- Do not treat the back sheet or front surface with paint or adhesives, to avoid reducing its' functionality, damage, inoperable conditions, and other unknown troubles.

### GENERAL SAFETY

Follow all permission, installation and inspection requirements.

- Before installing modules, contact the appropriate authorities to determine permissions, installation and inspection requirements, which should be followed.
- Be sure that the construction or structure (roof, etc.) where the modules are being installed has enough strength.
- For modules mounted on roofs, special construction or structures may be required to help provide proper installation support.
- Both roof construction and module installation design have an effect on the fire resistance of a building. Improper installation may contribute to fire hazards. Additional devices such as ground fault, fuses, and disconnects may be required.
- Do not use modules of different specifications in the same system.
- Follow all safety precautions of other system components used.

### INSTALLATION

#### General

- Please read this guide completely before installation or use of the modules. This section contains electrical and mechanical specifications needed before using modules.
- Modules should be firmly fixed in place in a manner suitable to withstand all expected loads, including wind and snow loads.
- Please do not touch the glass surface of modules to protect from dirt, because the glass surface is coated. (If the glass surface becomes dirty, see section of MAINTENANCE.)
- The drilling and addition of ground holes is permitted, but should be avoided whenever possible to

avoid damage to the module. When additional ground holes are necessary, they must not penetrate the inner side of the aluminum frame. Caution is advised to avoid accidentally drilling, scratching, or penetrating the back sheet surface of the module. If required, it is recommended to add additional ground holes to the outer aluminum lip area of the module. In such case, additional ground holes must be at least 65 mm away from any frame corner.

- For a non-integral module or panel, the assembly is to be mounted over a fire resistant roof covering rated for the application.
- Appropriate material should be used for mounting hardware to prevent the module frame, mounting structure, and hardware itself from corrosion.
- Install modules where they are not shaded by obstacles like buildings and trees. Especially pay attention to avoid partially shading the modules by objects during the daytime.
- Please contact your SANYO Authorized Representative with questions regarding mounting profiles for modules if needed.

### Notes on Installation

- Clearance of "10 cm" between the roof surface and module frame is required to allow cooling air to circulate around the back of the module. This also allows any condensation or moisture to dissipate. Install modules so that air can circulate between the roof and the module.
- We recommend installation methods shown in Figure 2. In some areas, local electrical codes may govern the installation and use of modules.
- To avoid the hazard of the electric shock and fire, do not contact and damage the back sheet of the module with mounting bolts.

### Operating Conditions

SANYO recommends that modules be operated within the following Operating Conditions. An installation location with conditions beyond the Operating Conditions or with other Special Conditions (see below) should be avoided. Operating Conditions of Panasonic HIT PV modules are as follows:

- 1) The modules should be operated only in terrestrial applications. No space or other Special Conditions (see below).
- 2) The ambient temperature should be within  $-20^{\circ}\text{C}$  ( $-4^{\circ}\text{F}$ ) to  $40^{\circ}\text{C}$  ( $104^{\circ}\text{F}$ ).
- 3) The relative humidity should be within 45% to 95%.
- 4) The wind pressure load of the installation site should be less than  $2,400\text{N/m}^2$  (50PSF).

### Special Conditions

- 1) The ambient temperature and installation place are different from the recommended Operating Conditions.
- 2) Salt damage is severe at the installation place.
- 3) Hail and snow damage is excessive at the installation place.
- 4) Sand and dust damage is excessive at the installation place.
- 5) Air pollution, chemically active vapors, acid rain, and/or soot, etc. are excessive at the installation place.

### SPECIFICATIONS

#### Notes on Specifications

- 1) Rated electrical characteristics are within 10% of the values measured at Standard Test Conditions (STC). Irradiance of  $1000\text{W/m}^2$ ,  $25^{\circ}\text{C}$  cell temperature, and solar spectral irradiance per IEC 60904-3.
- 2) Under normal conditions, a module may experience conditions that produce more current and/or voltage than reported at standard component test conditions. Accordingly, the values of  $I_{sc}$  and  $V_{oc}$  should be multiplied by a factor of 1.25 when determining voltage ratings, conductor capacities, fuse sizes, and size of controls connected to the module output.
- 3) The current output for the modules shown in the Specifications is measured at Standard Test Conditions. These conditions may not be frequently observed in actual practice.

### Application class of product

Panasonic HIT PV modules are applied to application class A. Application class A for PV-modules are defined as follows:

Class A: General access, hazardous voltage, hazardous power applications

Module rated for use in this application class may be used in systems operating at greater than 50 V DC or 240 W, where general contact access is anticipated. Modules qualified for safety through this part of IEC 61730-1 and IEC 61730-2 and within this application class are considered to meet the requirements for safety class II.

### Fire class of product

Panasonic HIT PV modules fill the fire class C that provides to ANSI/UL790. Class C roof coverings are effective against light fire test exposures. Under such exposures, roof coverings of this class afford a light degree of fire protection to the roof deck, do not slip from position, and are not expected to produce flying brands.

### Mechanical Loading

- The modules should be mounted basically at the four (4) quarter points by the means shown in Figure 1-1 or 1-4. However, you may choose the optional mounting ranges (with limitation of fixing span) by means shown in Figure 1-2 or Figure 1-3 for VBHNxxxSE series, in Figure 1-4 or 1-5 for VBHHxxxAE series.
- This method offers a maximum load of  $2400\text{N/m}^2$  (50PSF, in a static state) on the module surface.

### CERTIFICATION

VBHNxxxSE series and VBHHxxxAE series comply with the requirements of IEC61215, IEC61730-1, IEC61730-2 and the CE mark.

### WIRING

#### General

- All wiring should be done in accordance with applicable electrical codes.
- All wiring should be done by a qualified, licensed professional.
- Wiring should be protected to help ensure personal safety and to prevent its damage.
- All modules connected in series should be of the same model number and/or type.
- Do not connect modules in parallel without using a connection box.
- Do not disconnect terminals while modules generate electricity and connect electrical load to avoid the hazard of electrical shock.
- To avoid the hazard of electric shock and sparks, please connect

each cable after confirming the polarity of them is correct.

- Cable conduits should be used in locations where the wiring is inaccessible to children or small animals.

### Module Wiring

- The maximum number of VBHNxxxSE series that can be wired in series is sixteen (16).
- The maximum number of VBHHxxxAE series that can be wired in series is twenty (20).
- Modules shall not be wired in parallel without maximum over current protection.
- When installing a PV array, the system design must be completed with reference to the module electrical specifications for proper selection of inverters, fuses, breakers, charging controllers, batteries and other storage devices.
- These modules contain factory installed bypass diodes. If these modules are connected each other incorrectly, the bypass diodes, cable, or junction box may be damaged.

### Array Wiring

- The term "array" is used to describe the assembly of several modules on a support structure with associated wiring.
- Use copper wire that is sunlight resistant and is insulated to withstand the maximum possible system open circuit voltage.
- Check your local codes for requirements.

### Earth Ground Wiring

- The kind of the earth construction shall conform to IEC61730-1.
- Bonding shall be by a positive means, such as clamping, riveting, bolted or screwed connections, or welding, soldering or brazing. The bonding connections shall penetrate all non-conductive coatings, such as paint, anodized coatings or vitreous enamel.
- A wiring terminal or bonding location of module intended to accommodate a field installed equipment-grounding conductor shall be identified with the appropriate symbol (IEC 60417-5019(DB: 2002-10)) or shall have a green-colored part.
- Grounding should be carried out by the attachment to the module or

array frame, to avoid the hazards of electric shock or fire.

### Module Terminations

- A junction box as a terminal enclosure is equipped for electrical connections on Panasonic modules.
- Modules are equipped with MC™ plugs or SMK plugs as a terminal enclosure. Use these MC™ plugs or SMK plugs for electrical connections.
- If two or more separable connectors are provided, they shall be configured or arranged so that the other and vice-versa will not accept the mating connector for one, if it will result in an improper connection.
- Please contact your SANYO Authorized Representative with questions regarding other electrical connections if needed.

### Junction Box and Terminals

- Modules equipped with one junction box contain terminals for both positive and negative polarity, and bypass diodes.
- One terminal is dedicated to each polarity (with the polarity symbols engraved onto the body of the junction box) (see Figure 3-1 or 3-2).

### Conduit

- For applications where wire conduits are used, follow the applicable codes for outdoor installation of wires in conduits. Minimum diameter of wire conduit is 4 mm<sup>2</sup>.
- Verify that all fittings are properly installed to protect wires against damage and prevent moisture intrusion.

### DIODES

#### Bypass Diodes

- When the modules in series strings are shaded partially, it may cause reverse voltage across cells or modules, because the current from other cells in the same series is forced to flow through the shaded area. This may cause undesirable heating to occur.
- The use of a diode to bypass the shaded area can minimize both heating and array current reduction.
- All modules are equipped with factory installed bypass diodes. The factory installed diodes provide proper circuit protection for the

systems within the specified system voltage, so that you do not need any other additional bypass diodes.

- Specifications of bypass diode for VBHNxxxSE series are as follows; Number of bypass diode: 3 diodes, Number of series cells per bypass diode: 24 cells / diode (See Figure 4-1).
- Specifications of bypass diode for VBHHxxxAE series are as follows; Number of bypass diode: 3 diodes, Number of series cells per bypass diode: 96 cells / diode (1st and 3rd block, 2 parallels of 48 cells series), 48 cells / diode (2nd block, 2 parallels of 24 cells series) (See Figure 4-2).
- Contact your SANYO Authorized Representative for proper diode type, if it is necessary to add or change diodes due to system specifications.

### MAINTENANCE

- Some maintenance is recommended to maintain optimal output performance of the solar modules.
- If the module surface becomes dirty, it may reduce output power.
- It is recommended to clean the surface of the module with water and a soft cloth or sponge.
- To remove persistent dirt, the module can be washed with a micro-fiber cloth and ethanol.
- Alternatively, a mild detergent may be used. Never use abrasive detergent, strong alkaline detergent and strong acid detergent to clean any part of the module.
- It is also recommended to inspect the electrical and mechanical connections annually.
- If you need electrical or mechanical inspection or maintenance, it is recommended to have a licensed authorized professional carry out the inspection or maintenance to avoid the hazards of electric shock or injury.
- The return of any modules will not be accepted by SANYO unless prior written authorization has been given by SANYO.
- As part of our policy of continuous improvement SANYO reserves the right to change product specifications at any time without prior notice.

**Disclaimer of Liability**

SANYO does not assume responsibility and expressly disclaims liability for loss, damage, or expense arising out of, or in any way connected with installation, operation, use, or maintenance by using this manual.

SANYO assumes no responsibility for any infringement of patents or other rights of third parties, which may result from use of modules.

No license is granted by implication or under any patent or patent rights. The information in this manual is believed to be reliable, but does not constitute an expressed and/or implied warranty. SANYO reserves the right to make changes to the product, specifications, or manual without prior notice.

**Customer Services**

For further information, please visit [eu-solar.panasonic.net](http://eu-solar.panasonic.net) or contact a SANYO Authorized Representative.

© SANYO Electric Co., Ltd. 2012  
All Rights Reserved Apr. 3. 2012

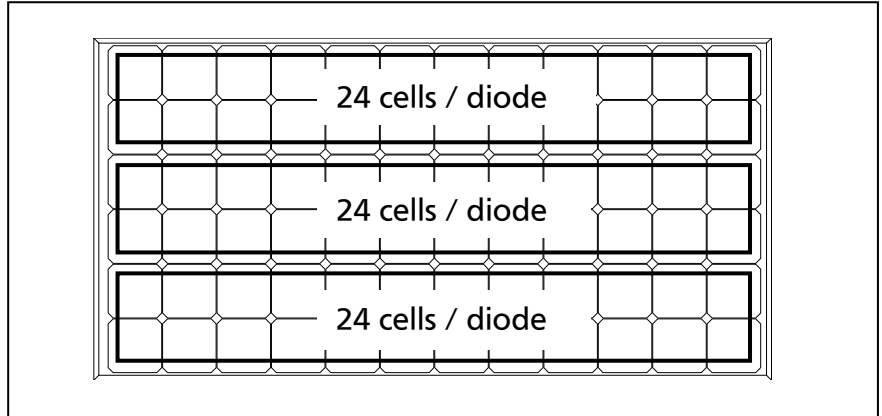

Figure 4-1: Number of series cells per bypass diode

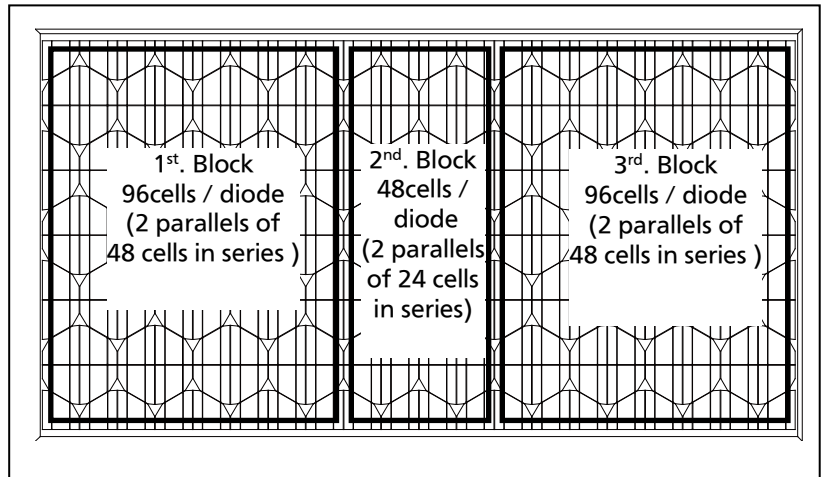

Figure 4-2: Number of series cells per bypass diode

## SPECIFICATIONS

Standard Models – VBHNxxxSE10, VBHNxxxSE11

### Electrical Specifications

Model		VBHN240SE10 VBHN240SE11	VBHN235SE10 VBHN235SE11	VBHN230SE10 VBHN230SE11
Cell Number in Series		72	72	72
Rated Power, Watts (Pmax)	W	240	235	230
Maximum Power Voltage (Vpm)	V	43.7	43.0	42.3
Maximum Power Current (Ipm)	A	5.51	5.48	5.45
Open Circuit Voltage (Voc)	V	52.4	51.8	51.2
Short Circuit Current (Isc)	A	5.85	5.84	5.83
Cell Type		HIT*	HIT*	HIT*
Maximum System Voltage (Voc)	V	1000	1000	1000
Maximum over-current protection	A	15	15	15
Factory Installed Bypass Diodes		3	3	3

HIT\* : Hetero junction with Intrinsic Thin-layer

### Mechanical Specifications

Model		HIT-N240SE10, HIT-N240SE11	VBHN235SE10 VBHN235SE11	VBHN230SE10 VBHN230SE11
Length	mm	1580		
Width	mm	798		
Height	mm	35		
Weight	kg	15		

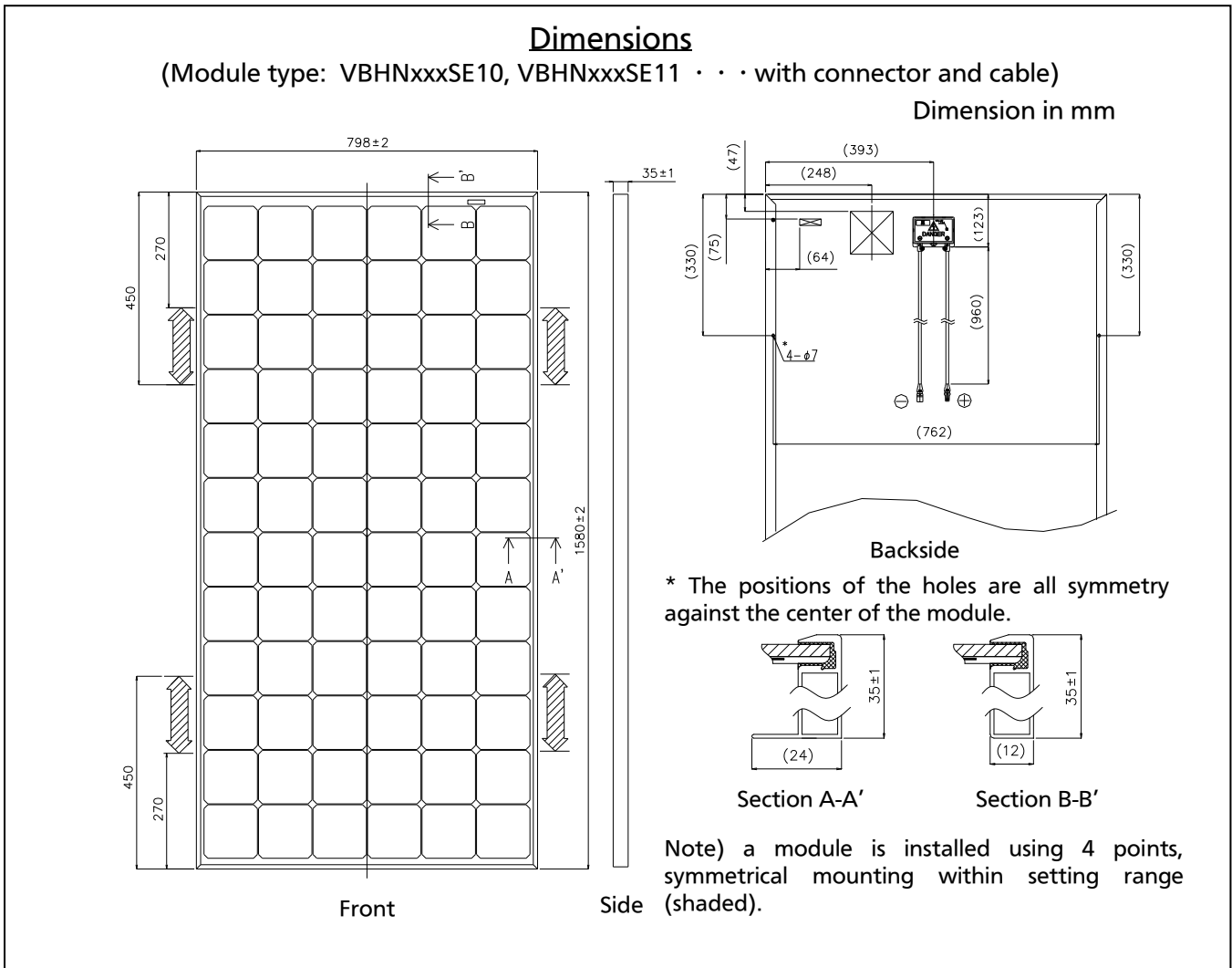

Figure 1-1: Dimensions

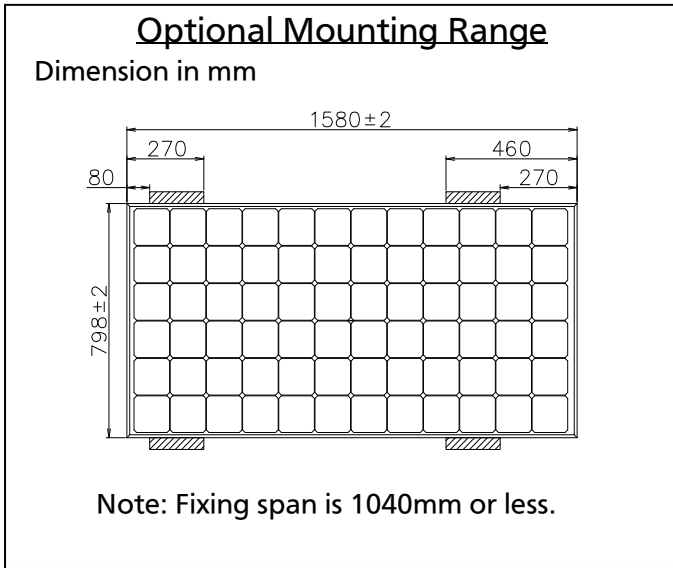

Figure 1-2: Optional Mounting Range

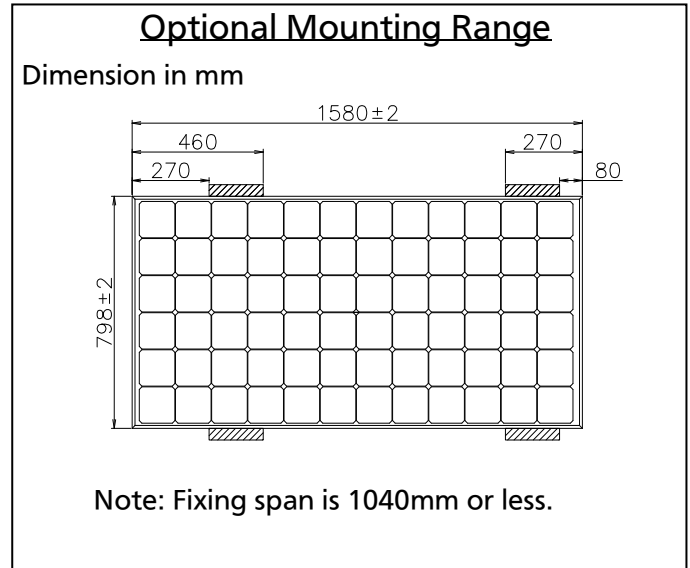

Figure 1-3: Optional Mounting Range

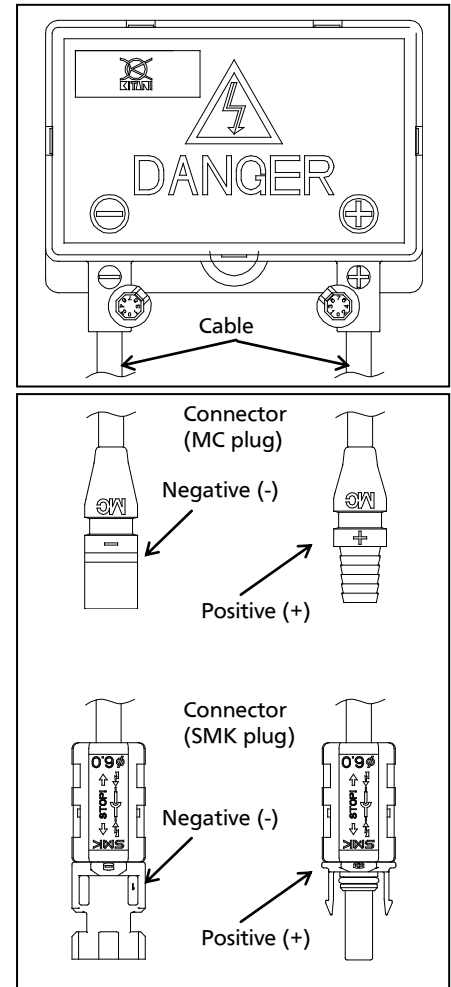
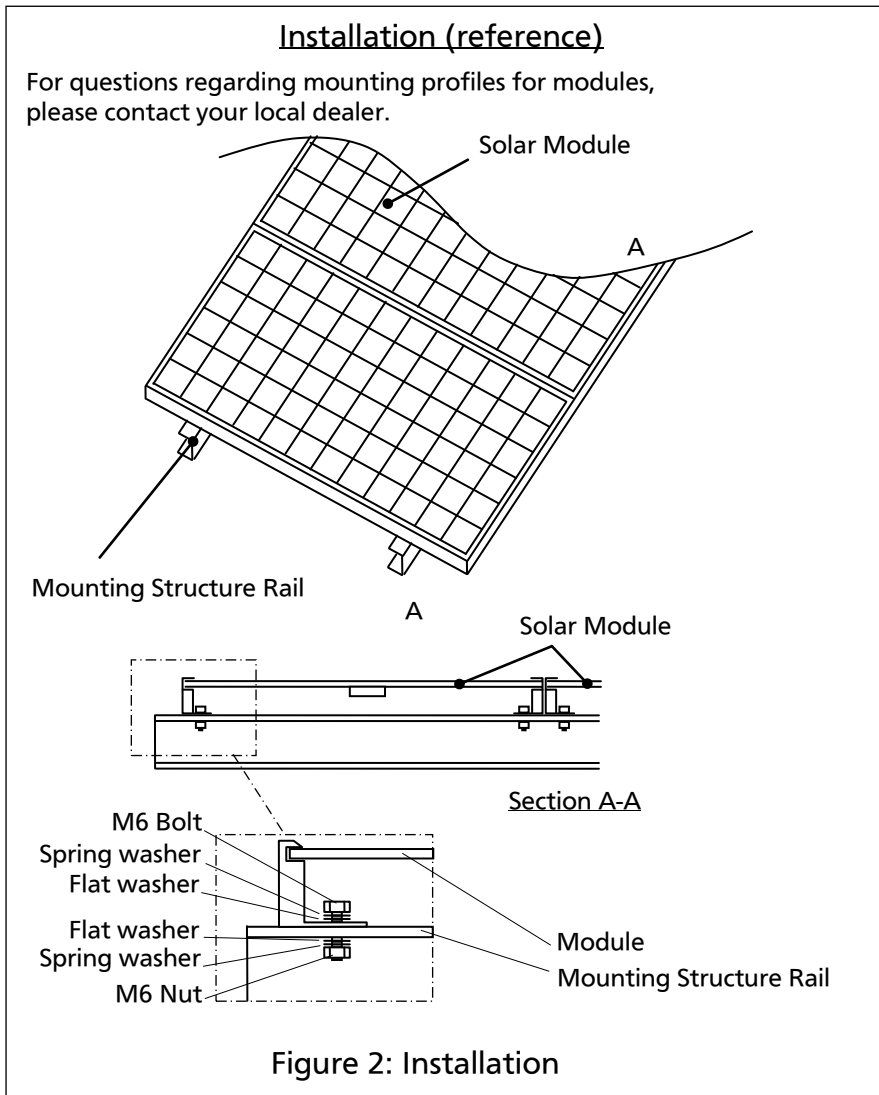

Figure 3-1: Configuration of Junction Box

## SPECIFICATIONS

Standard Models – VBHHxxxAE01, VBHHxxxAE02

### Electrical Specifications

Model		VBHH250AE01 VBHH250AE02	VBHH245AE01 VBHH245AE02	VBHH240AE01 VBHH240AE02
Cell Number in Series		60	60	60
Total cell number		240	240	240
Rated Power, Watts (Pmax)	W	250	245	240
Maximum Power Voltage (Vpm)	V	34.9	34.4	33.8
Maximum Power Current (Ipm)	A	7.18	7.14	7.11
Open Circuit Voltage (Voc)	V	43.1	42.7	42.3
Short Circuit Current (Isc)	A	7.74	7.73	7.72
Cell Type		HIT*	HIT*	HIT*
Maximum System Voltage (Voc)	V	1000	1000	1000
Maximum over-current protection rating	A	15	15	15
Factory Installed Bypass Diodes		3	3	3

HIT\* : Hetero junction with Intrinsic Thin-layer

### Mechanical Specifications

Model		VBHH250AE01 VBHH250AE02	VBHH245AE01 VBHH245AE02	VBHH240AE01 VBHH240AE02
Length	mm	861		
Width	mm	1610		
Height	mm	35		
Weight	kg	16.5		

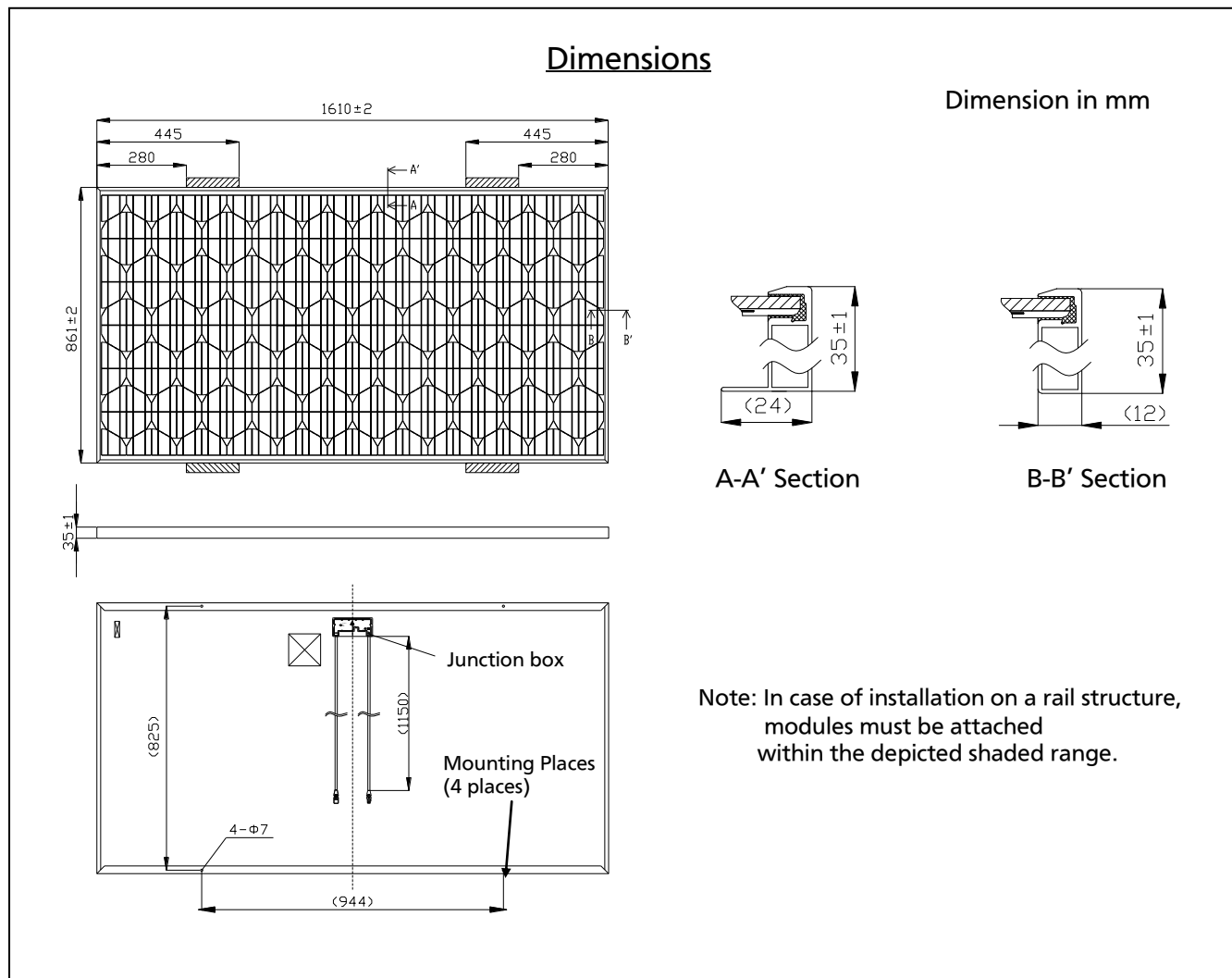

Figure 1-4: Dimensions



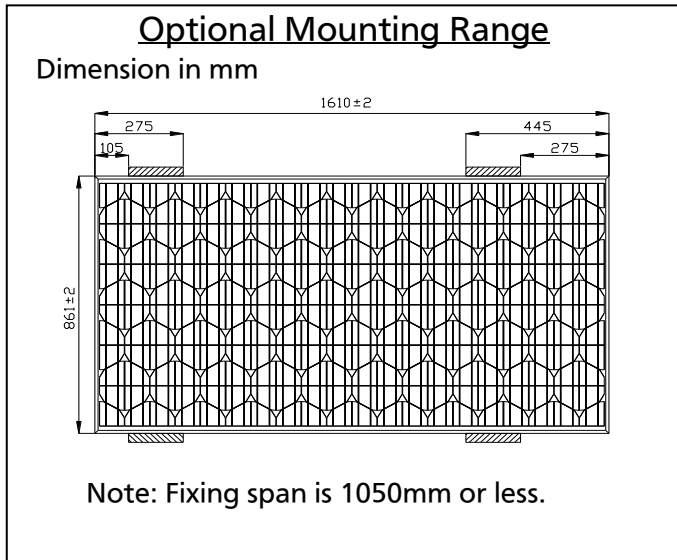

Figure 1-5: Optional Mounting Range

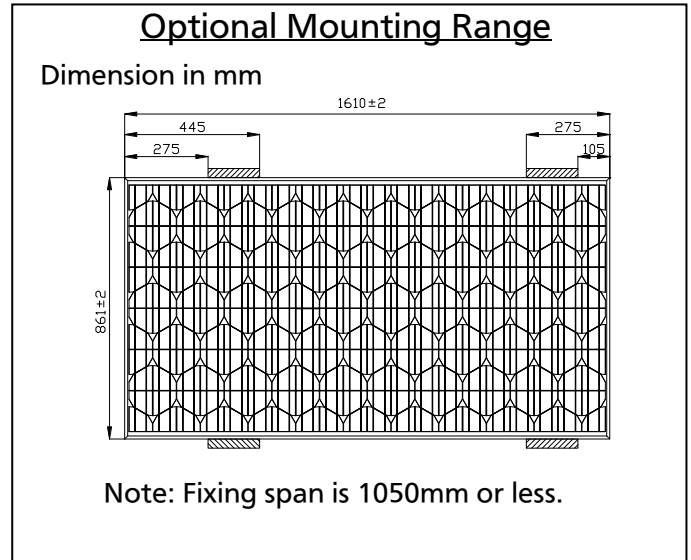

Figure 1-6: Optional Mounting Range

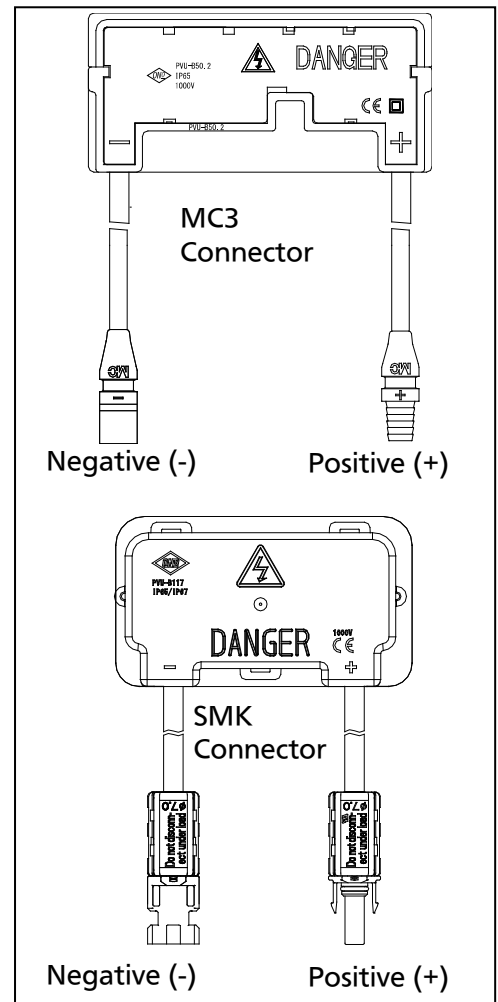
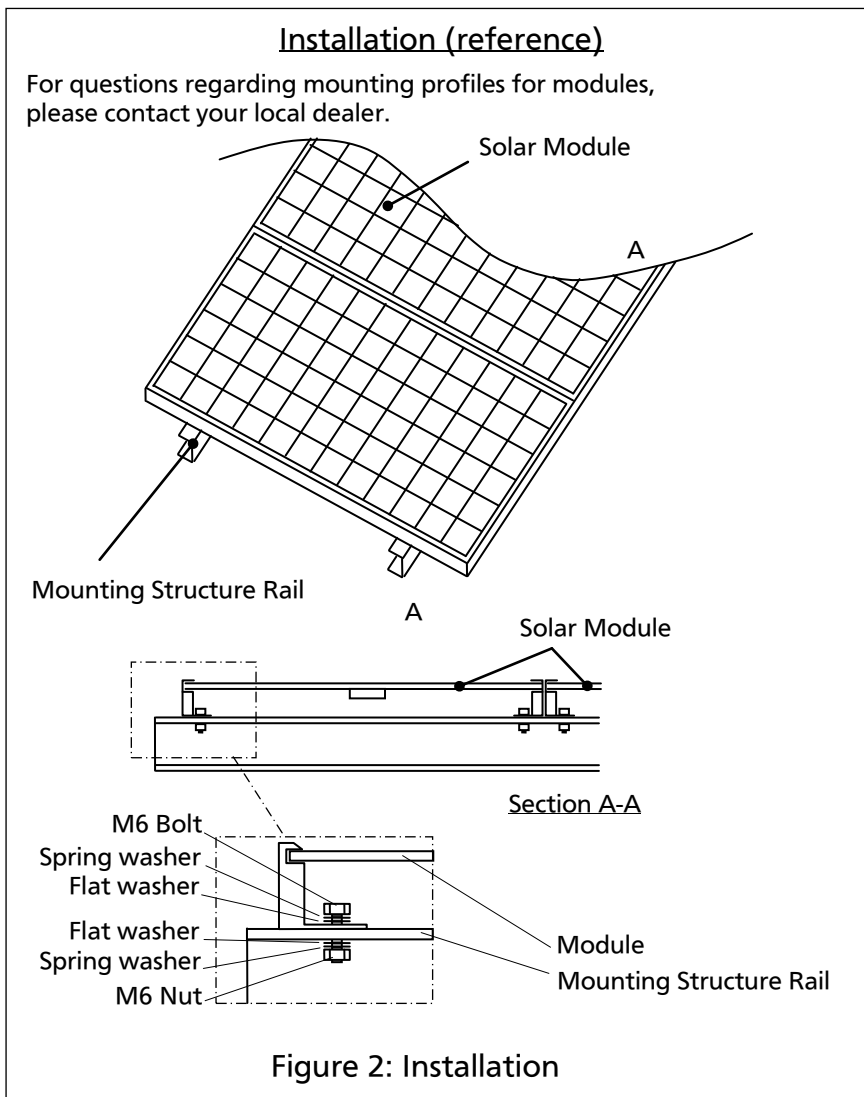

Figure 3-2: Configuration of Junction box